

Multilevel Inverter by Cascading Industrial VSI

Remus Teodorescu, *Senior Member, IEEE*, Frede Blaabjerg, *Senior Member, IEEE*,
John. K. Pedersen, *Senior Member, IEEE*, Ekrem Cengelci, and Prasad N. Enjeti, *Fellow, IEEE*

Abstract—In this paper, the modularity concept applied to medium-voltage adjustable speed drives is addressed. First, the single-phase cascaded voltage-source inverter that uses series connection of insulated gate bipolar transistor (IGBT) H-bridge modules with isolated dc buses is presented. Next, a novel three-phase cascaded voltage-source inverter that uses three IGBT triphase inverter modules along with an output transformer to obtain a 3-p.u. multilevel output voltage is introduced. The system yields in high-quality multistep voltage with up to four levels and low dv/dt , balanced operation of the inverter modules, each supplying a third of the motor rated kVA. The concept of using cascaded inverters is further extended to a new modular motor-modular inverter system where the motor winding connections are reconnected into several three-phase groups, either six-lead or 12-lead connection according to the voltage level, each powered by a standard triphase IGBT inverter module. Thus, a high fault tolerance is being achieved and the output transformer requirement is eliminated. A staggered space-vector modulation technique applicable to three-phase cascaded voltage-source inverter topologies is also demonstrated. Both computer simulations and experimental tests demonstrate the feasibility of the systems.

Index Terms—Medium-voltage adjustable-speed drives, modulation strategies, multilevel converters.

I. INTRODUCTION

UNTIL A FEW years ago, the gate-turn-off thyristor (GTO) current-source inverter (CSI) was considered as the standard topology used in high-power applications. Series connection of GTO's enabled output line voltage as high as 6 kV to be obtained along with the advantages of natural power regeneration due to the thyristor-controlled line converter and efficient short-circuit overcurrent protection ability.

Only recently, due to the emergence of high-voltage power devices such as the integrated gate-commutated thyristor (IGCT) or HV insulated gate bipolar transistor (IGBT) with voltage ratings up to 3.9 and 4.5 kV, respectively, commercially available, a general trend of replacing GTO-CSI by neutral-point-clamped (NPC) voltage-source inverters (VSI) in both active and reactive high-power applications came forth. NPC-based drives are currently available at ratings up to 6700 hp/4.16 kV. A recent survey [1] over the North American

Manuscript received June 28, 2001; revised October 29, 2001. Abstract published on the Internet May 16, 2002. This paper was presented at the IEE Seminar on PWM Medium Voltage Drives, Birmingham, U.K., May 11, 2000.

R. Teodorescu, F. Blaabjerg and J. K. Pedersen are with the Institute of Energy Technology, Department of Electrical Energy Conversion, Aalborg University, DK-9220 Aalborg East, Denmark (e-mail: ret@iet.auc.dk).

E. Cengelci is with the Tyco Electronics Power Systems, Mesquite, TX 75149-1802 USA. (e-mail: ekrem.cengelci@tycoelectronics.com).

P. N. Enjeti is with the Power Quality Laboratory, Department of Electrical Engineering, Texas A&M University, College Station, TX 77843 USA (e-mail: enjeti@ee.tamu.edu).

Publisher Item Identifier 10.1109/TIE.2002.801069.

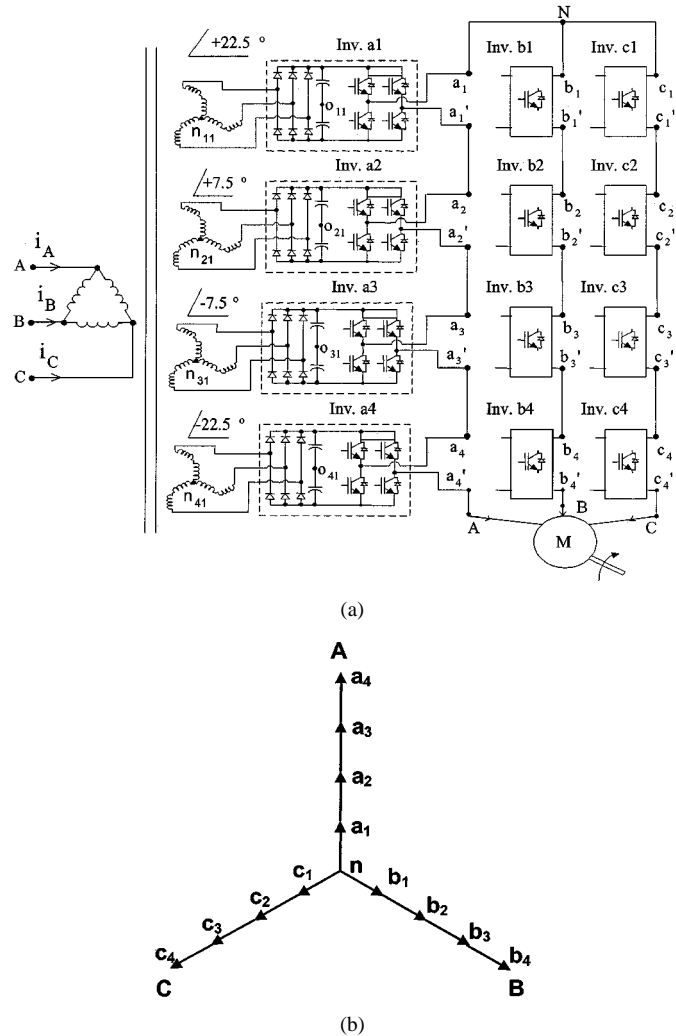

Fig. 1. (a) 4.16-kV SC-VSI ASD with $U_d = 850$ V and 48 IGBTs rated 1700 V (36 IGBTs rated 1700 V for 2.3-kV ASD). (b) Voltage-vector diagram for the SC-VSI.

medium-voltage (MV) adjustable-speed drives (ASDs) used in the petrochemical industry revealed that over 76% are covered by 4.16-kV drives and about 20% by 2.3-kV drives. Therefore, in this paper, only these two ratings will be considered, with most of our focus on the former one.

A novel approach in multilevel conversion technology is the use of series connection of two-level VSI with relative phase shifting, viewed as building block power modules [2]–[4]. Thus, not only a drastic reduction in voltage stress across the devices but also an improved maintenance due to modularity concept are achieved. The power modules can be either single-phase VSI or three-phase VSI. Single-phase cascaded (SC) VSI drives are now available with ratings up to 10 000 hp/6 kV [4].

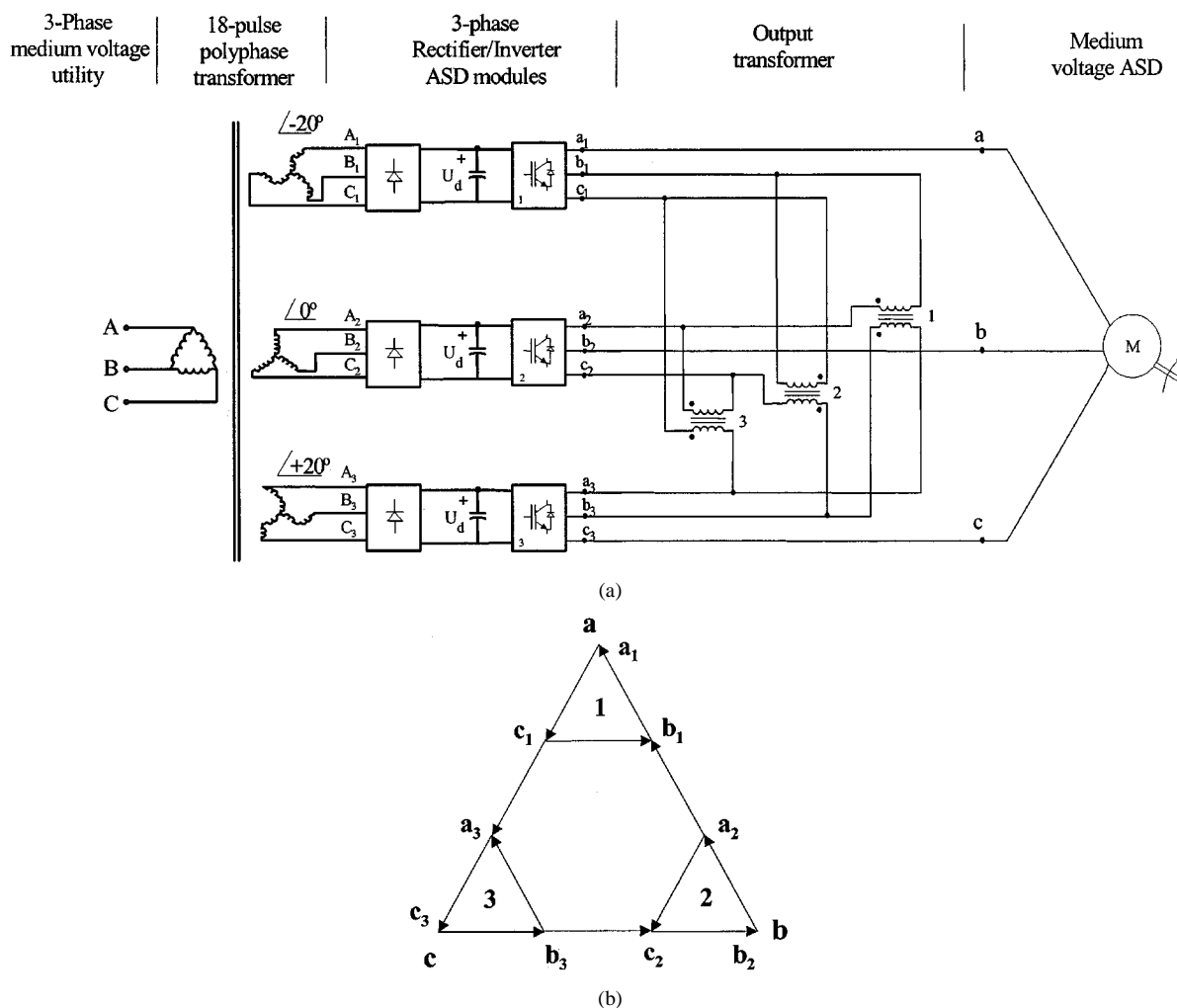

Fig. 2. (a) 4.16-kV TC-VSI ASD with $U_d = 2000$ V and 18 IGBTs rated 3.300 V (18 IGBTs rated 1700 V for 2.3-kV ASD). (b) Voltage-vector diagram for the TC-VSI.

Due to the fact that the multilevel output voltage exhibits lower dv/dt and harmonic distortion in comparison with the two-level voltage, typical problems related to the two-level VSI drives like stator winding insulation breakdown, bearing failures, and high electromagnetic interference (EMI) associated to the high switching frequency can be much diminished when using multilevel technology.

The goals of this paper are to describe two new topologies: three-phase cascaded (TC)-VSI and modular motor-modular inverter (MM-MI) that can be used in the MV-ASD area and to demonstrate their performance by both computer simulation and practical experiments.

II. SC VSI DRIVE SYSTEM

Formerly proposed in [4] and [5], the SC-VSI topology uses series-connected low voltage 1700-V IGBT H-inverter bridges with 850-V dc bus. The MV ASD described in [4] uses nine modules (three per phase) for 2.3-kV ASD and 12 (four per phase) for 4.16 kV ASDs, respectively. This modular structure leads to important advantages such as: lower cost per kilowatt due to the cheaper IGBT technology, power scalability, built-in redundancy, and easy maintenance. Fault tolerance can be achieved by bypassing the fault modules.

The main drawbacks are: high dc-link capacitive energy storage requirement especially in constant torque applications and a special expensive transformer with 18 pulses/nine secondary windings for the 2.3-kV ASD and 24 pulses/12 windings for the 4.16-kV ASD, respectively, required to provide the isolated dc buses (see Fig. 1).

III. TC VSI DRIVE SYSTEM

The novel TC-VSI topology described in [6] and [7] and depicted in Fig. 2 uses three standard IGBT-VSI along with a 0.33-p.u. (kVA) output transformer to achieve a 3-p.u. (V) output multilevel voltage.

The main advantages of this system can be summarized as follows:

- a 3-p.u. (V) pulsewidth modulation (PWM) output line voltage, as can be seen in Fig. 7(a), with up to four levels exhibiting low dv/dt and total harmonic distortion (THD);
- balanced operation of each inverter that supply 0.33-p.u. (kVA);
- modular construction, yielding easy maintenance;
- no circulating currents between the inverter modules.

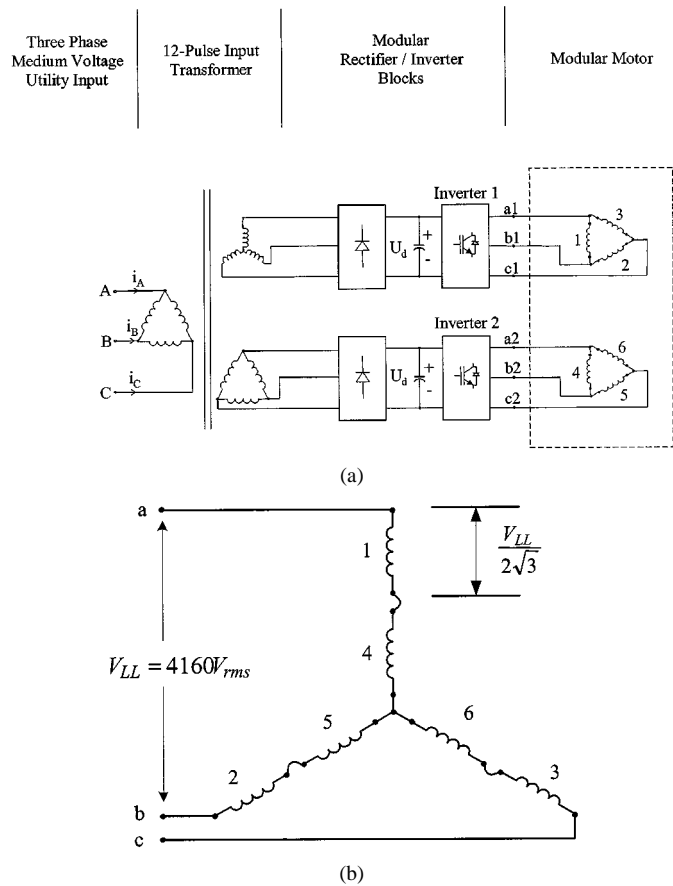

Fig. 3. (a) 4.16-kV MM-MI ASD (two-pole motor), $U_d = 1700$ V, 12 IGBTs/3300 V (12 IGBTs/1700 V for 2.3 kV). (b) Voltage vector diagram for the MM-MI.

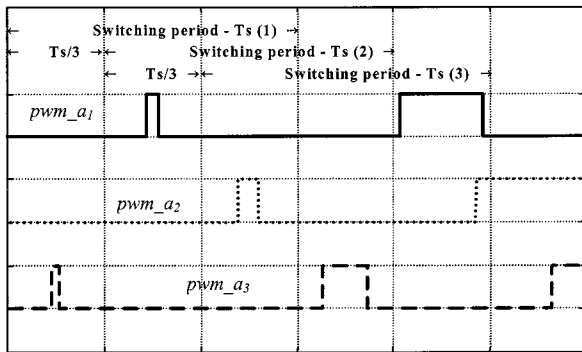

Fig. 4. SSVM pulse-generation technique for the case of triphase cascaded (TC)-VSI.

In order to obtain multistep output voltage phase-shift modulation strategies need to be used (see Section V). The main drawback remains the extra cost of the output transformer, although it is rated only one third of the total load kVA. An 18 pulses/three secondary winding input transformer is required to provide a clean line interface.

IV. MM-MI DRIVE SYSTEM

The windings of the MV motors are usually arranged in a number of group coils equal to the pole number of the motor [8]. Star connection is used for 4.16-kV line voltage whereas

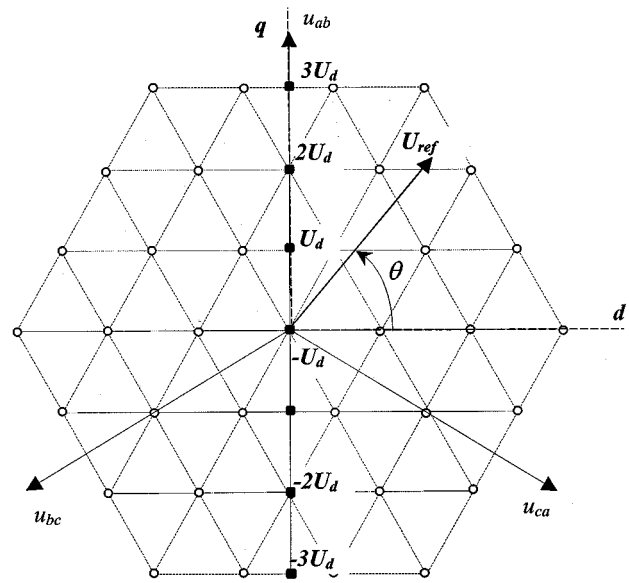

Fig. 5. Voltage reference vector and the 36 possible switching states of the TC-VSI.

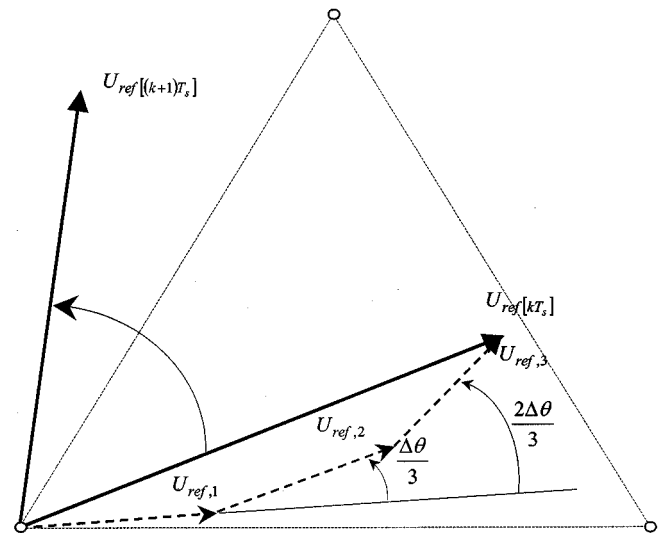

Fig. 6. SSVM reference voltage vectors.

delta connection is used for a 2.3-kV line voltage ASD. The MM-MI concept proposes the reconnection of the motor windings in two possible ways: six-lead and 12-lead connections. In Fig. 3, a complete MM-MI ASD with a two-pole motor connected in six-lead connection is shown. Thus, two delta-grouped motor windings are available and fed by two triphase IGBT inverter modules. In this case, the voltage rating of each inverter is decreased to $(V_{LL}/2\sqrt{3})$ where V_{LL} denotes the supply line voltage. In the case of a 4.16-kV, two 1200-V inverter modules are required.

In the case of four-pole motors, a 12-lead connection can be used in conjunction with four triphase inverter modules. In this case, the voltage rating of each inverter is decreased to $(V_{LL}/4\sqrt{3})$ i.e., four inverters rated 600 V are required for a 4.16-kV ASD. MV motors with eight or 12 poles can also be connected in 12-lead connection by grouping the coils in four delta-connected motor winding groups.

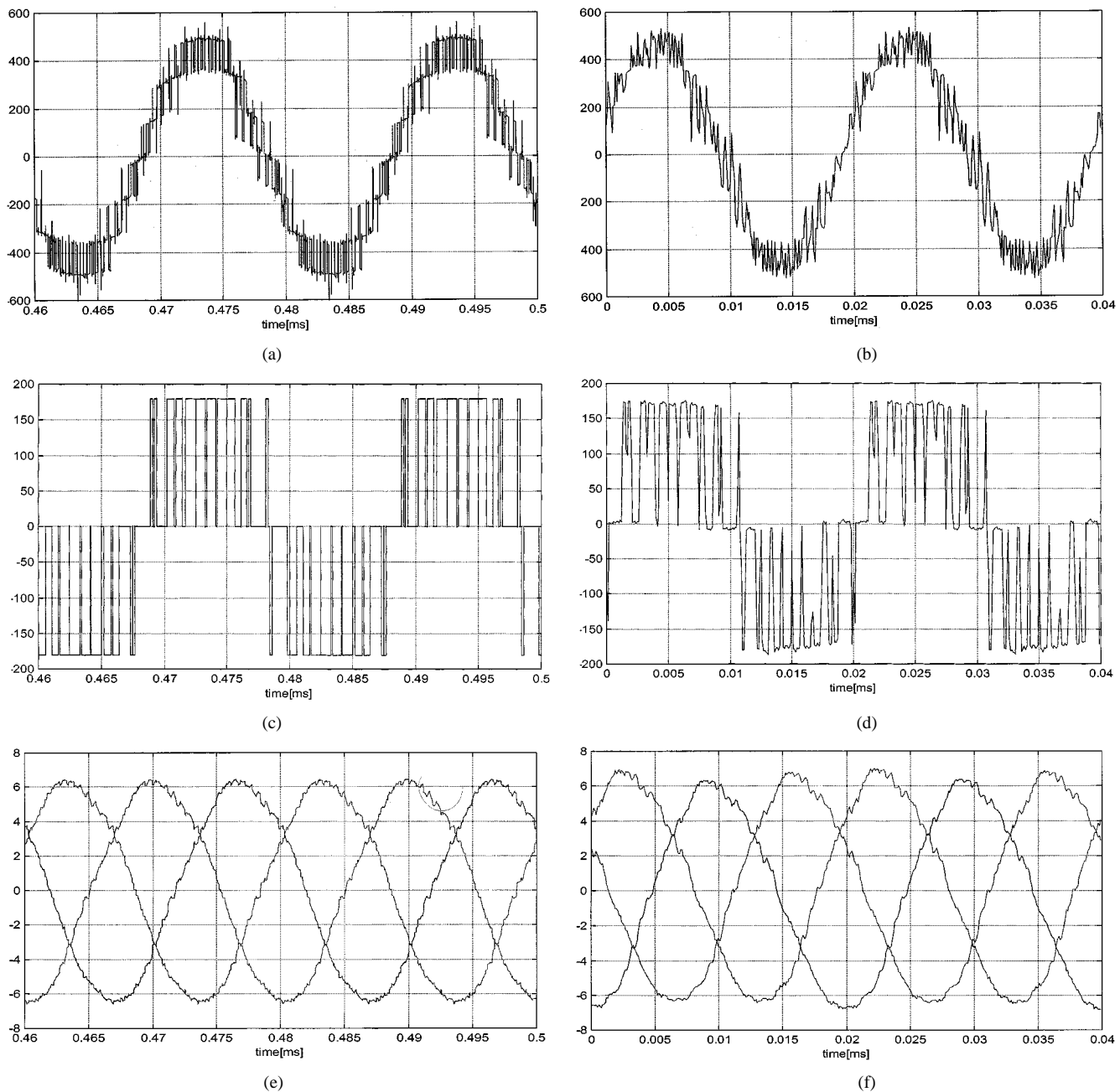

Fig. 7. Exp. and sim. results obtained with an SSVM-controlled TC-VSI-fed ASD with the parameters: $f_s = 600$ Hz, $m = 0.95$, $f = 50$ Hz, $U_d = 120$ V, 2.2-kW 400 V/Y induction motor, at half rated load. (a) Motor line voltage (sim.). (b) Motor line voltage (exp.). (c) VSI output line voltage (sim.). (d) VSI output line voltage (exp.). (e) Motor line currents (sim.). (f) Motor line currents (exp.).

The MM-MI concept brings the following major advantages.

- The voltage insulation requirement of the motor/inverter is reduced by 3.5 with the six-lead connection and by 7 with 12-lead motor connection.
- The structure exhibits a high level of reliability due to its inherent redundancy and fault tolerance.
- Under inverter/motor fault with the 12-lead connection structure, it is possible to phase-shift the remaining inverters in order to cancel the magnetomotive force (MMF) harmonics resulting from partial winding excitation.
- The possibility of using it in automotive applications where the voltage levels are limited and MM-MI connection could permit a higher equivalent voltage on the motor and lead to lower currents; adaptation to different

torque–speed characteristics is also possible by changing different winding connections.

The main disadvantage remains the fact that the MV motor requires a reconnection of the windings, but this can manually be achieved especially as most of the MV motors comes with multi-terminals (six or 12 terminals) for soft-starting purposes.

V. MODULATION STRATEGIES FOR CASCADED VSI TOPOLOGIES

One well-used modulation strategy used in multilevel MV converter with cascaded modules is multicarriers sine triangle with third harmonic (MSTH) [9] where, for n cascaded VSI, n triangular carriers with a relative phase shift of T_s/n , where T_s

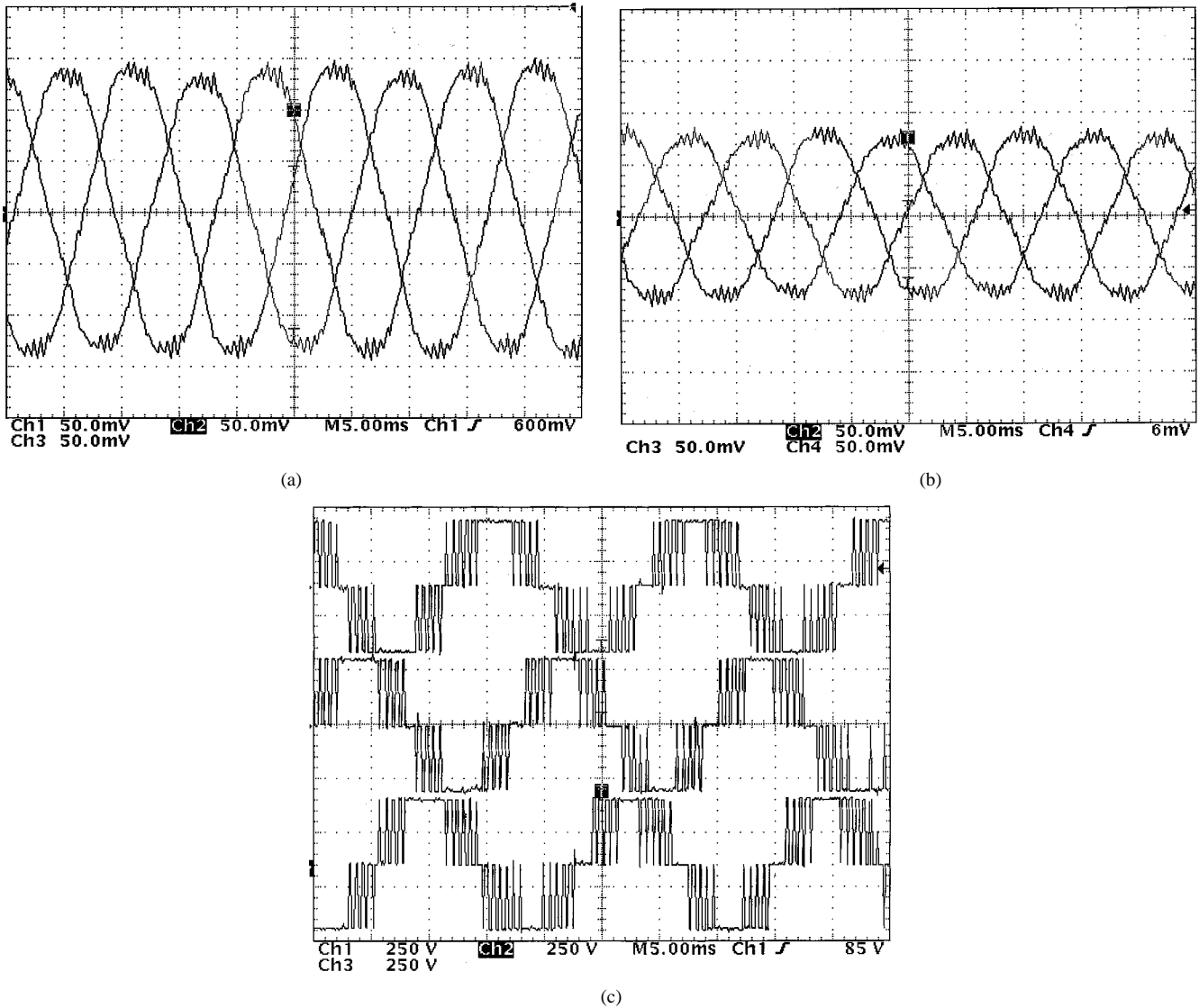

Fig. 8. Exp. results obtained with an MM-MI ASD using a 230-V/460-V 60-Hz 10-hp six-pole induction motor reconnected in six-lead configuration. (a) Line-to-line output voltage of inverter-1, V_{a1b1} , V_{b1c1} , and V_{c1a1} , 250 V/div. (b) Output current of inverter-1, I_{a1} , I_{b1} , and I_{c1} , 5 A/div. (c) Output current of inverter-1 I_{a1} , I_{b1} , and I_{c1} , 5 A/div while inverter-2 is shut down.

denotes the switching period, are compared against the same reference in order to generate the desired switching instants. When adding the staggered output voltages, a $(2n + 1)$ -level phase output voltage is achieved, with the first group of harmonics centered around triplen switching frequency.

A novel staggered space-vector modulation (SSVM) scheme that brings the benefits of the space-vector theory has also been proposed in [9]. For n cascaded VSI, n time basis with T_s/n relative shift is generated. The SVM algorithm is performed n times for duty-cycle calculations in each VSI, due to the fact that the reference is different in each shifted carrier period (Fig. 4).

All the 36 active switching states of the TC-VSI are represented in Fig. 5 along with the voltage reference vector. One can easily observe that four levels in the line voltage, i.e., 0 , $\pm U_d$, $\pm 2U_d$, and $\pm 3U_d$ result by projecting the active switching states (points) over the respective axes, e.g., u_{ab} . By varying the modulation index, the number of levels decrease from four to three at $m = 0.66$ and from three to two at $m = 0.33$. This is advantageous because the motor voltage stress is even further reduced at lower fundamental frequencies. The reference voltage U_{ref} is

achieved by adding the references of each of the n VSI with a $\Delta\theta/3$ relative phase shift, as shown in Fig. 6 and expressed in (1)

$$U_{ref} = \sum_{n=1}^3 U_{ref,n}. \quad (1)$$

Since the reference vector is sampled three times at different angles in each modulator, the equivalent switching frequency in the output voltage is three times higher than that in each VSI, as it is also the case for MSTH.

VI. EXPERIMENTAL RESULTS

A. Three-Phase Cascaded (TC)-VSI

A complete TC-VSI was simulated using the SABER [10] computer simulator, where three two-level VSI models along with the output transformers were simulated taking into account the measured primary-secondary windings parasitic capacitance, leakage, and magnetizing inductance. A MAST

template [10] was developed in order to implement the SSVM algorithm. Next, an experimental setup was built using three 4-kVA/400-V IGBT-VSI commercially available inverters supplying a 2.2-kW/400-V/Y/two-pole induction motor. Three 1-kVA 240-V/240-V single-phase common transformers were used as output transformers. Since clean line interface was not of first concern, three 5-kVA $3 \times 400\text{-V}/3 \times 400\text{-V}$ common transformers were used to provide isolated dc-buses, instead of a special 18 pulse/three windings transformer. A mixed digital signal processor (DSP)/microcontroller platform consisting of SAB 80C167 MCB-167 and ADSP 21 062 EZ-Lab development kit was used for control implementation.

Simulation (sim.) and experimental (exp.) results are shown in Fig. 7. Fig. 7(a) and (b) depicts the line output voltage from simulation and experiment, respectively. The four-level waveform yielding low dv/dt and low harmonics distortion can be observed. Next, in Fig. 7(c) and (d), the VSI two-level line voltage is presented. Finally, motor currents are shown in Fig. 7(e) and (f), where low harmonic distortion is achieved at a low switching frequency, i.e., 600 Hz. These results demonstrate the advantages of using the new TC-VSI concept in MV ASD, i.e., low harmonic content in output voltages and currents, low switching frequency, and low dv/dt .

B. MM-MI

The MM-MI concept proposed in Fig. 2 was implemented on a laboratory prototype using a 230-V/460-V 60-Hz 10-hp six-pole induction motor reconnected in six-lead configuration. Two commercially available inverters were modified for this purpose.

Because the line interface was not of first concern, no 12 pulse/two secondary windings input transformer was used. Instead, both rectifiers are supplied from the same line as the two motor delta windings are electrically isolated.

Fig. 8(a) shows the currents I_{a1} , I_{b1} , and I_{c1} supplied by inverter-1 under no-load condition (inverter-2 currents are almost identical).

Fig. 8(b) shows the PWM output voltage of inverter-1 and Fig. 8(c) depicts the same currents when inverter-2 is shut down. As can be observed, the currents are higher, but the ASD is kept going. Thus, it features a high level of fault tolerance by being able to work at half load with one inverter shut down.

VII. CONCLUSIONS

In this paper, the modularity concept applied to an MV-ASD has been addressed. Instead of connecting the switching devices in series in order to achieve MV requirements, multiple inverter modules can be cascaded. Thus, low-voltage low-cost IGBT technology can be applied. SC-VSI technology is already available on the market and it is considered as a reference in this study for cost and performance in respect to two common MV-ASD ratings, i.e., 2.3 and 4.16 kV.

The novel TC-VSI topology that employs three standard IGBT triphase inverter modules along with an output transformer to achieve a high-quality 3-p.u. multistep output voltage is introduced. A 2.2-kW/400-V motor laboratory test rig shows low harmonic distortion motor current even if the inverters are switched with 600 Hz.

A novel MM-MI concept was introduced where the MV motor windings need to be reconnected in several delta groups, each powered by separate triphase inverter module. The resulting system is fault tolerant and is able to operate at a reduced power level under inverter/motor faults. Experimental results demonstrate the performance of a 10-hp/460-V motor laboratory prototype. In comparison with the SC-VSI, the MM-MI concept requires lower dc-link capacitive energy storage and uses a reduced number of IGBTs with the same voltage rating but higher current rating (the same kVA). Although it requires a special motor reconnection the insulation requirement is much lowered leading to cost reduction in MV motor technology.

An SSVM technique that can be applied for triphase cascaded topologies was also demonstrated.

Both TC-VSI and MM-MI computer simulations and experimental tests have demonstrated the feasibility of these systems.

REFERENCES

- [1] R. A. Hanna and S. Prabhu, "Medium-voltage adjustable-speed drives—users' and manufacturers' experiences," *IEEE Trans. Ind. Applicat.*, vol. 33, pp. 1407–1415, Nov./Dec. 1997.
- [2] Y. Shakweh and E. A. Lewis, "Assessment of medium voltage PWM VSI topologies for multi-megawatt variable speed applications," in *Proc. IEEE PESC'99*, 1999, pp. 965–972.
- [3] R. Teodorescu, F. Blaabjerg, J. K. Pedersen, E. Cengelci, S. U. Sulstijo, B. O. Woo, and P. Enjeti, "Multilevel converters—A survey," in *Proc. EPE'99*, 1999, CD-ROM.
- [4] R. H. Osman. A comparison of popular medium-voltage motor drives robicon technical document. [Online] <http://www.robicon.com>
- [5] P. W. Hammond, "Medium voltage PWM drive and method," U.S. Patent 5 625 545, Apr. 29, 1997.
- [6] Texas A&M University, "Method and System of medium voltage inverter topologies for adjustable speed AC motor drive systems," U.S. Patent Application, 1998.
- [7] E. Cengelci, S. U. Sulstijo, B. O. Woo, P. Enjeti, R. Teodorescu, and F. Blaabjerg, "A new medium voltage PWM inverter topology for adjustable-speed drives," *IEEE Trans. Ind. Applicat.*, vol. 35, pp. 628–637, May/June 1999.
- [8] E. Cengelci, P. Enjeti, and W. Gray, "A new modular motor—Modular inverter (MM-MI) concept for medium voltage adjustable speed drive systems," in *Conf. Rec. IEEE-IAS Annu. Meeting*, vol. 3, 1999, pp. 1972–1979.
- [9] R. Teodorescu, F. Blaabjerg, J. K. Pedersen, P. Enjeti, and E. Cengelci, "Space vector modulation applied to modular multilevel converters," in *Proc. PCIM'99, Intelligent Motion*, vol. 35, 1999, pp. 363–368.
- [10] *Saber Reference Manual, Release 4.1*, Analog Inc., Norwood, MA, 1998.



Remus Teodorescu (S'94–M'99–SM'02) was born in Galati, Romania, in 1965. He received the Dipl. Ing. degree in electrical engineering from the Polytechnical University of Bucharest, Bucharest, Romania in 1989, and Ph.D. degree in power electronics from the University of Galati, Galati, Romania, in 1994.

From 1989 to 1990, he was with the Iron and Steel Plant Galati. He then joined Galati University where he was initially an Assistant in the Electrical Engineering Department. In 1994, he became an Assistant

Professor and, in 1996, he was appointed as the Head of the Power Electronics Research Group. In 1998, he joined the Power Electronics and Drives Department, Institute of Energy Technology, Aalborg University, Aalborg East, Denmark, where he is currently a Research Associate Professor. He has authored more than 36 published papers, one book, and one patent. His areas of interests include digital control and computer simulations of advanced electrical drives, power converters, and medium-voltage drives.

Dr. Teodorescu was the co-recipient of the 1998 Technical Committee Prize Paper Award from the IEEE Industry Applications Society and of the Third OPTIM 2002-ABB Prize Paper Award.



Frede Blaabjerg (S'86-M'88-SM'97) was born in Erslev, Denmark, in 1963. He received the M.Sc. E.E. from Aalborg University, Aalborg East, Denmark in 1987, and the Ph.D. degree from the Institute of Energy Technology, Aalborg University, in 1995.

He was with ABB-Scandia, Randers, from 1987 to 1988. In 1992, he became an Assistant Professor at Aalborg University, where, in 1996, he became an Associate Professor and, in 1998, he became a Full Professor of Power Electronics and Drives. In 2000, he was a Visiting Professor at the University

of Padova, Italy, as well as a part-time Programme Research Leader at the Research Center Risoe, working on wind turbines. His research areas are power electronics, static power converters, ac drives, switched reluctance drives, modeling, characterization of power semiconductor devices and simulation, wind turbines, and green power inverters. He is engaged in more than 15 research projects with industry, including the Danfoss Professor Programme in Power Electronics and Drives. He is the author or coauthor of more than 250 publications in his research fields. He is an Associate Editor of the *Journal of Power Electronics* and the Danish journal, *Elteknik*. He has served as a member of the Danish Technical Research Council since 1997 and, in 2001, he became Chairman. He is Chairman of the Danish Small Satellite programme and the Center Contract Committee which support collaboration between universities and industry.

Dr. Blaabjerg is a member of the European Power Electronics and Drives Association and the Industrial Drives, Industrial Power Converter, and Power Electronics Devices and Components Committees of the IEEE Industry Applications Society. He is also an Associated Editor of the IEEE TRANSACTIONS ON INDUSTRY APPLICATIONS and IEEE TRANSACTIONS ON POWER ELECTRONICS. He became also a member of the Danish Academy of Technical Science in 2001. He received the 1995 Angelos Award for his contribution to modulation technique and control of electric drives and an Annual Teacher Prize from Aalborg University, also 1995. In 1998, he received the Outstanding Young Power Electronics Engineer Award from the IEEE Power Electronics Society. He has received four IEEE Prize Paper Awards within the last four years.



John K. Pedersen (M'91-SM'00) was born in Holstebro, Denmark, in 1959. He received the B.Sc. E.E. degree from Aalborg University, Aalborg East, Denmark.

He was with the Institute of Energy Technology, Aalborg University, as a Teaching Assistant from 1983 to 1984, as an Assistant Professor from 1984 to 1989. He has been an Associate Professor since 1989. He is also the Head of the Institute of Energy Technology. His research areas are power electronics, power converters, and electrical drive

systems, including modeling, simulation, and design with a focus on optimized efficiency.

Mr. Pedersen received the 1992 Angelos Award for his contribution to the control of induction machines. In 1998, he received an IEEE TRANSACTIONS ON POWER ELECTRONICS Prize Paper Award for the best paper published in 1997.



Ekrem Cengcelci received the B.Sc. degree in electronics and telecommunication engineering from Yildiz Technical University, Istanbul, Turkey, in 1993, the M.S. degree in electric power engineering from Rensselaer Polytechnic Institute, Troy, NY, in 1996, and the Ph.D. degree in electrical engineering from Texas A&M University, College Station, in 2000.

He is currently with Tyco Electronics Power Systems, Mesquite, TX.

Mr. Cengcelci received two Second Prize Paper Awards from the Industrial Power Converter Committee and the Industrial Drives Committee of the IEEE Industry Applications Society in 1998 and 1999, respectively.



Prasad N. Enjeti (M'85-SM'88-F'00) received the B.E. degree from Osmania University, Hyderabad, India, the M.Tech degree from Indian Institute of Technology, Kanpur, India, and the Ph.D. degree from Concordia University, Montreal, QC, Canada, in 1980, 1982, and 1988, all in electrical engineering.

In 1988, he joined the Department of Electrical Engineering, Texas A&M University, College Station, as an Assistant Professor. In 1994, he was promoted to Associate Professor and, in 1998, he became a full Professor. His primary research interests are advance

converters for power supplies and motor drives, power quality issues and active power filter development, converters for fuel cells, microturbine wind energy systems, power electronic hardware for flywheels, ultracapacitor-type energy storage/discharge devices for ride-through, and utility interface issues. He is the holder of four U.S. patents and has licensed two new technologies to the industry. He is the Lead Developer of the Power Quality and Distributed Energy Systems Laboratory at Texas A&M University and is actively involved in many projects with industry, while engaged in teaching, research, and consulting in the areas of power electronics, motor drives, power quality, and clean power utility interface issues.

Dr. Enjeti was the recipient of Second Best Paper Awards in 1993, 1998, 1999, and 2001, and a Third Best Paper Award in 1996 from the IEEE Industry Applications Society (IAS). He received the Second Prize Paper Award from the IEEE TRANSACTIONS ON INDUSTRY APPLICATIONS for papers published from mid-year 1994 to mid-year 1995 and the *IEEE Industry Applications Magazine* Prize Article Award in the year 1996. He is a Member of the IAS Executive Board and the Chair of the Standing Committee on "Electronic Communications." He was also the recipient of the select title "Class of 2001 Texas A&M University Faculty Fellow" for demonstrated achievement of excellence in research, scholarship, and leadership in the field. He directed a team of students to design and build a low-cost fuel cell inverter for residential applications, which won the 2001 Future Energy Challenge Award, Grand Prize, from the U.S. Department of Energy. He is a Registered Professional Engineer in the State of Texas.